

Cam Action Indexing Plungers

Steel, Latch Plastic, Plunger Pin in Standard Position Protruded

SPECIFICATION

Types

- Type **A**: Without rest position, without lock nut
- Type **AK**: Without rest position, with lock nut
- Type **R**: With rest position, without lock nut
- Type **RK**: With rest position, with lock nut
- Type **S**: With safety-rest position, without lock nut
- Type **SK**: With safety-rest position, with lock nut

Guide

Steel zinc plated, blue passivated

Plunger pin

Stainless steel AISI 303

Latch

- Plastic, Polyamide (PA)
- Black, matte finish
- Not removable



INFORMATION

Cam action indexing plungers GN 712 are used in such applications where the plunger pin must not protrude continually. When turning the cam by 90° resp. 120° degrees in anti-clockwise direction, the plunger pin is retracted through a curved opening in the body.

Depending on the type, the plunger pin is moved back by a pressure spring in its original position (Type A), is held in retracted position (Type R), resp. is secured against accidental operation (Type S). In order to move the plunger pin, this safety version requires an additional lifting of the latch.

ON REQUEST

- Guide in stainless steel

TECHNICAL INFORMATION

- Range of Cam Action Indexing Plungers (see page 816)
- Load Rating Information (see page A42)
- ISO Fundamental Tolerances (see page A21)
- Metric ISO thread (see page A19)
- Plastic Characteristics (see page A2)
- Stainless Steel Characteristics (see page A26)

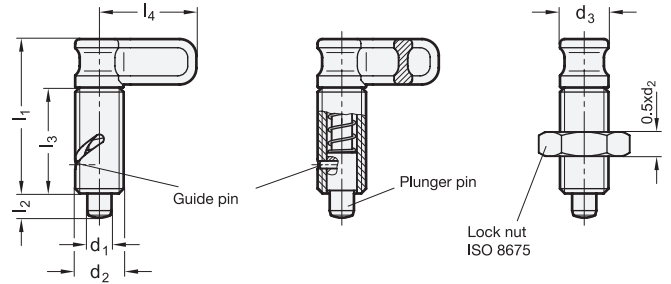

Plunger pin retracted

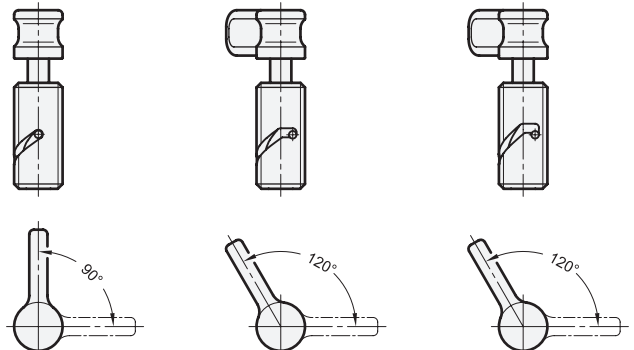

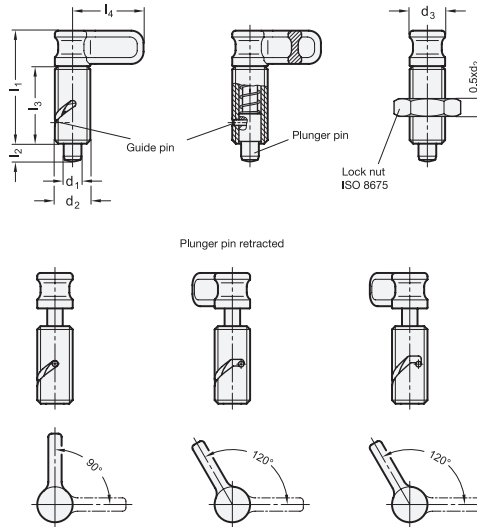

GN 712-A

Description	d1 Pin h9 Bore +0.03/+0.1	d2	d3	l1 ≈	l2	l3 min.	l4	Spring load in N ≈ Initial	Spring load in N ≈ End	⚖️
GN 712-6-M16x1,5-A	6	M 16 x 1.5	16	51	8	35	32	6.5	20	50
GN 712-8-M16x1,5-A	8	M 16 x 1.5	16	51	8	35	32	6.5	20	52
GN 712-10-M16x1,5-A	10	M 16 x 1.5	16	51	8	35	32	6.5	20	55

GN 712-AK

Description	d1 Pin h9 Bore +0.03/+0.1	d2	d3	l1 ≈	l2	l3 min.	l4	Spring load in N ≈ Initial	Spring load in N ≈ End	⚖️
GN 712-6-M16x1,5-AK	6	M 16 x 1.5	16	51	8	35	32	6.5	20	68
GN 712-8-M16x1,5-AK	8	M 16 x 1.5	16	51	8	35	32	6.5	20	70
GN 712-10-M16x1,5-AK	10	M 16 x 1.5	16	51	8	35	32	6.5	20	72

GN 712-R

Description	d1 Pin h9 Bore +0.03/+0.1	d2	d3	l1 ≈	l2	l3 min.	l4	Spring load in N ≈ Initial	Spring load in N ≈ End	⚖️
GN 712-6-M16x1,5-R	6	M 16 x 1.5	16	51	8	35	32	6.5	20	50
GN 712-8-M16x1,5-R	8	M 16 x 1.5	16	51	8	35	32	6.5	20	52
GN 712-10-M16x1,5-R	10	M 16 x 1.5	16	51	8	35	32	6.5	20	55

GN 712-RK

Description	d1 Pin h9 Bore +0.03/+0.1	d2	d3	l1 ≈	l2	l3 min.	l4	Spring load in N ≈ Initial	Spring load in N ≈ End	⚖️
GN 712-6-M16x1,5-RK	6	M 16 x 1.5	16	51	8	35	32	6.5	20	60
GN 712-8-M16x1,5-RK	8	M 16 x 1.5	16	51	8	35	32	6.5	20	65
GN 712-10-M16x1,5-RK	10	M 16 x 1.5	16	51	8	35	32	6.5	20	70

GN 712-S

Description	d1 Pin h9 Bore +0.03/+0.1	d2	d3	l1 ≈	l2	l3 min.	l4	Spring load in N ≈ Initial	Spring load in N ≈ End	⚖️
GN 712-6-M16x1,5-S	6	M 16 x 1.5	16	51	8	35	32	6.5	20	50
GN 712-8-M16x1,5-S	8	M 16 x 1.5	16	51	8	35	32	6.5	20	52
GN 712-10-M16x1,5-S	10	M 16 x 1.5	16	51	8	35	32	6.5	20	55

GN 712-SK

Description	d1 Pin h9 Bore +0.03/+0.1	d2	d3	l1 ≈	l2	l3 min.	l4	Spring load in N ≈ Initial	Spring load in N ≈ End	⚖️
GN 712-6-M16x1,5-SK	6	M 16 x 1.5	16	51	8	35	32	6.5	20	60
GN 712-8-M16x1,5-SK	8	M 16 x 1.5	16	51	8	35	32	6.5	20	65
GN 712-10-M16x1,5-SK	10	M 16 x 1.5	16	51	8	35	32	6.5	20	70

